

GROSS LOAD CAPACITY WHEN USED AS A WEIGHT CARRYING HITCH: 5000 LBS. TRAILER WEIGHT & 500 LBS. TONGUE WEIGHT.
*****DO NOT EXCEED VEHICLE MANUFACTURER'S RECOMMENDED TOWING CAPACITY.*****

Parts List			
ITEM	QTY	PART NUMBER	DESCRIPTION
1	4	1_2 - 13 x 6	CARRIAGE BOLT
2	8	HFN 1213	HEX FLANGE NUT
3	2	CM-31297-SP	.375 x 1" INSTALLATION SPACER
4	4	CM-31297-SP1	.706 OD x .622 ID, SPACER

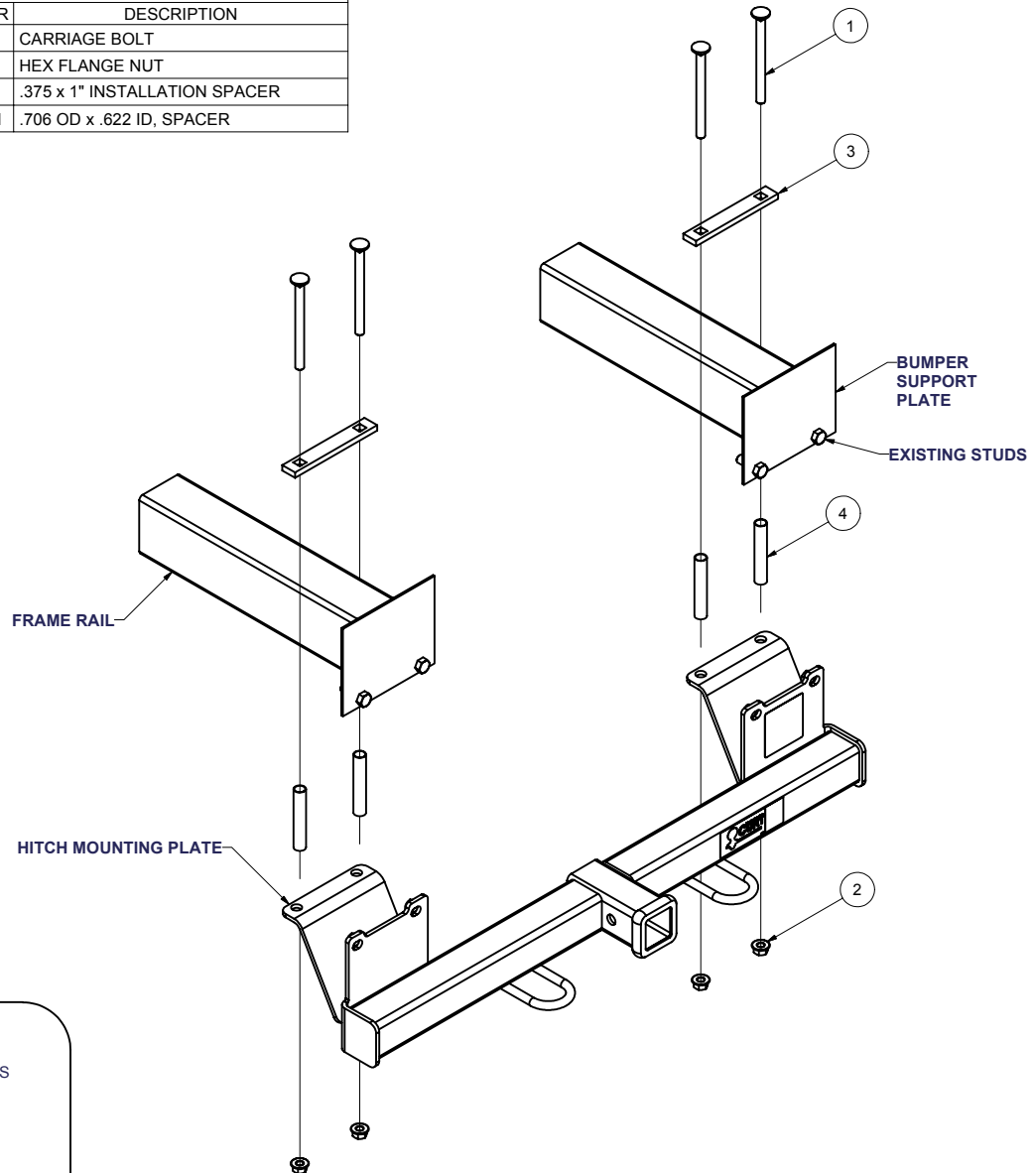

HITCH WEIGHT: 40 LBS.
 INSTALL TIME: 30 MINUTES
 INSTALL NOTES:
 NO DRILLING REQUIRED

INSTALLATION STEPS

- 1) Remove two lower flange nuts from the front bumper support studs.(Both sides)
- 2) Place carriage bolts into spacers provided and position them on top of vehicle frame rails.
- 3) Raise hitch into position over front bumper support studs and secure with existing flange nuts..
- 4) Place spacer tubes over the 1/2" carriage bolts bridging the span between the top of the frame rail and hitch mounting plate.
- 5) Install 1/2" flange nuts on carriage bolts and hand tighten.
- 6) Tighten all 1/2" fasteners to 75 lb-ft. and M10 fasteners to 35 lb-ft.

PERIODICALLY CHECK THIS RECEIVER HITCH TO ENSURE THAT ALL FASTENERS ARE TIGHT AND THAT ALL STRUCTURAL COMPONENTS ARE SOUND.